

Medical Assist Devices: Collaborative Projects

Dhananjay V. Gadre
Assistant Professor, ECE
Division, NSIT

dvgadre@gmail.com

<http://www.dvgadre.com>

Prosthetic Alignment System by Waag Society, Amsterdam

- ◆ Determination of weight bearing line when fitting and adjusting a prosthetic leg
- ◆ Commercial system (Ottobocks LASAR system) costs several thousand \$\$.
- ◆ First design uses FSR
- ◆ Collaboration between Waag Society, Amsterdam, Arctic Fablab, Norway and NSIT
- ◆ Final beneficiary: Yukkum Rehabilitasi, Yogyakarta and Jaipur Foot, Jaipur.

Current Design

- ◆ Uses Force Sensitive Resistors
- ◆ Cheap Microcontroller with stepper motor control to move a laser beam for weight line indication

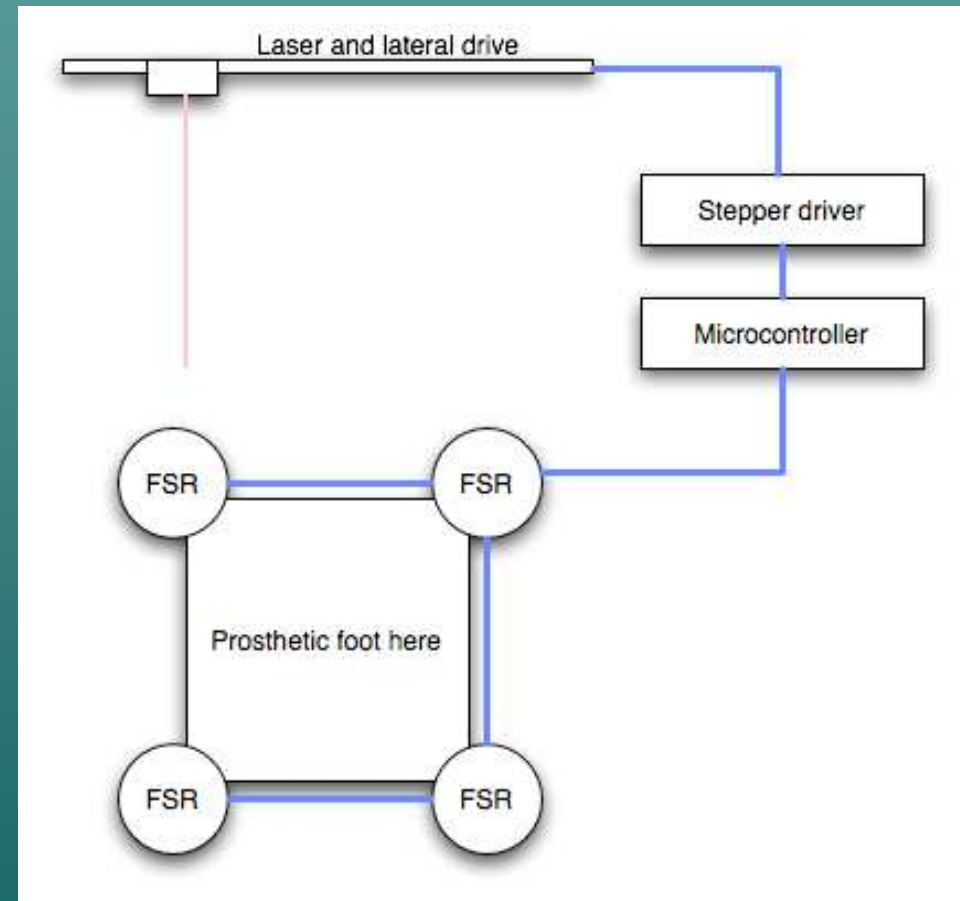

Proposed Modifications

Proposed design using rows and columns of electrodes with sandwiched elastic and dielectric material. Measure capacitance.

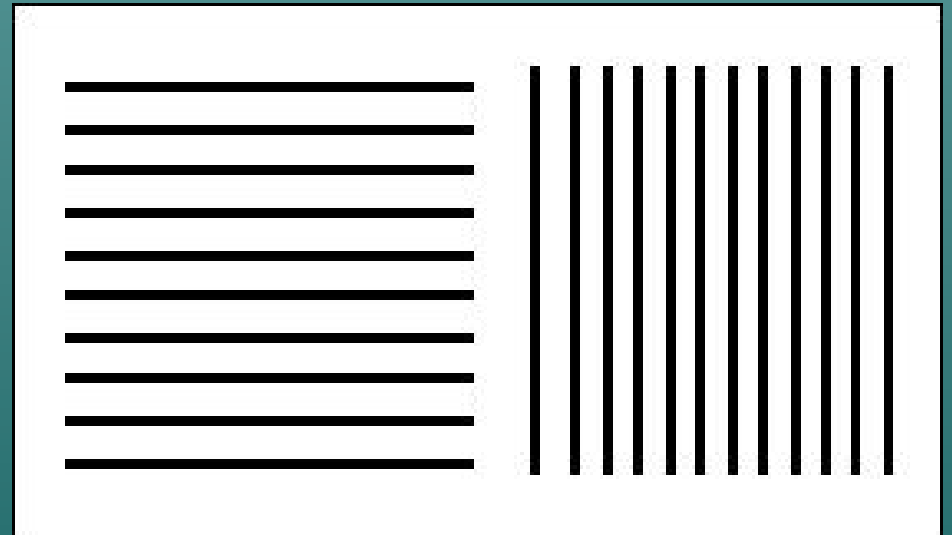

Novel and Inexpensive Pulseoximeter

- ◆ All current designs use precision analog components to record the plethysmograph.
- ◆ Based on our previous work on LEDs as sensors, a fully digital PPG.
- ◆ New approach reduces BOM Cost significantly ~ 200 rupees (5USD)

Fully Digital PPG

- ◆ Cheap AVR Microcontroller performs measurement and data processing
- ◆ 4 LEDs for illumination and sensing
- ◆ Graphics Display
- ◆ To Display Pulse Rate and SpO2

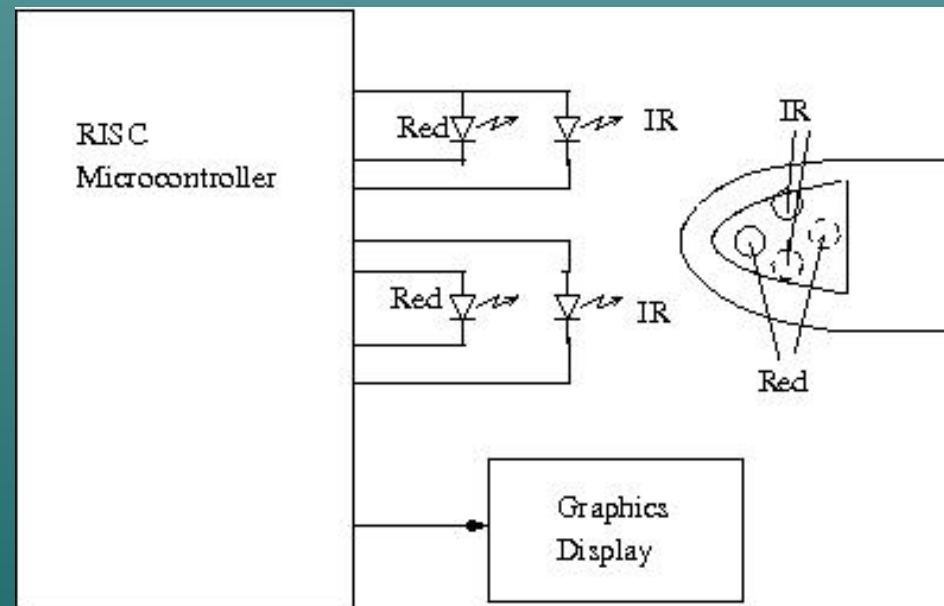

Thank you.

Questions?
Suggestions?

